

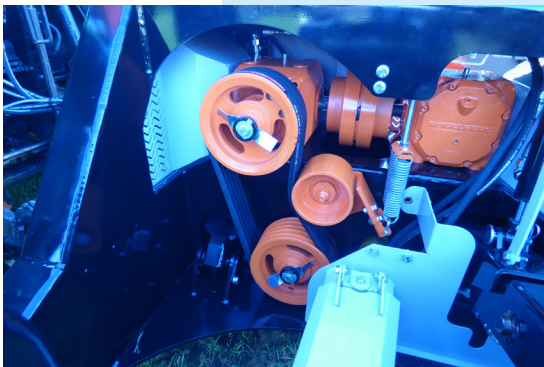

TRIPLE FLAIL MOWER

TRIHING



MAXIMUM EFFICIENCY, EXCELLENT OVERLAP

Heavy-duty combination of 3 flail toppers for cost effective working of large scale areas. For example set-aside land, fallow land, green manures, stubbles of corn, sunflowers etc.

A very efficient drive system for minimal power loss and adjustable rear hoods result in maximum efficiency and reduced fuel consumption.

**8.6 m working width with high efficiency drive system.
Maximum efficiency and reduced fuel consumption!**



TRIWING

Triple flail mower



The mid mower can be mounted in the tractor 3-pt. linkage with a special "pulled type" headstock. Or behind the two mid mowers at the special frame.

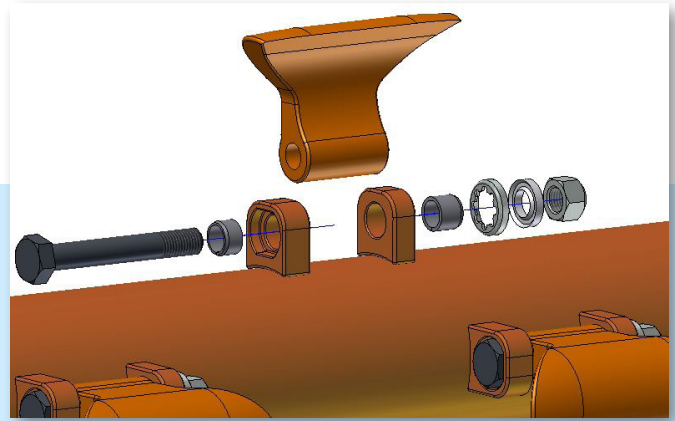

The standard 2,2 kg (5 lbs) special flails are fitted to the large diameter double balanced rotor with with heavy 20 mm bolts and replaceable steel bushes. PERFECT Combi-flails are optional avialbale.

MULTIPLE CONFIGURATIONS

Three heavy-duty mowing heads are mounted at a special frame which allows them to follow the ground contours independently. The rear mowers are equipped with a easily adjustable hydropneumatic ground pressure relief system.

Available as rear mount, front- and rear mount, front mount (reverse seat tractors or self propelled vehicles) or as a trailed version.

EXTRA'S

- Trailed version, wheels 15.0/55-75, including air brakes
- 0,9 kg flails
- 2,7 kg Combi-flails
- Pro-fix flai I mounting
- Chain protection instead of clacks
- Wearing plates



Technical specifications	TRIWING
Working width (cm/ inch)	860/ 28'2"
Speed: PTO shaft (rpm)	1000
Required min. power (kW/ HP)	185/250
Flails 2.2 (kg)/ 4.85 (lb)	56
Transport height (cm/ inch)	386 / 12'8"
Tractor coupling system (cat.)	III/IV
Weight 3-point model (kg/ lb)	4500 / 9000

As our policy is one of continuous improvement, we reserve the right to change the specification or to modify the desing without prior notice



Van Wamel B.V.

📍 **Van Wamel B.V.**
Energieweg 1, 6658 AE
Beneden Leeuwen
The Netherlands

☎ +31 (0) 487 59 29 44
☎ +31 (0) 487 59 29 44
@ www.vanwamel.nl
🌐 perfect@vanwamel.nl

Your **PERFECT** dealer